

- 1
- 2
- 3
- 4
- 5
- 6
- 7
- 8
- 9
- 10
- 11
- 12
- 13
- 14
- 15
- RH

MATERIAL

Polyamide based technopolymer (PA), black, orange colour, glossy finish.

BOSS CAP

Polyamide based (PA) technopolymer, RAL 7035 light grey colour (C3), matte finish.

STANDARD EXECUTION

- **VTR-B**: brass boss, threaded pass-through hole, with cap.
- **VTR-FP**: brass boss, threaded pass-through hole, without cap.
- **VTR-N**: square hole, without cap.
- **VTR-p**: zinc-plated steel threaded stud, chamfered flat end according to UNI 947 : ISO 4753 (see Technical data), with cap.

SPECIAL EXECUTIONS ON REQUEST

Knobs with cap in standard colours: black (C9), orange (C2), yellow (C4), light-blue (C5), red (C6).



ELESA Original design

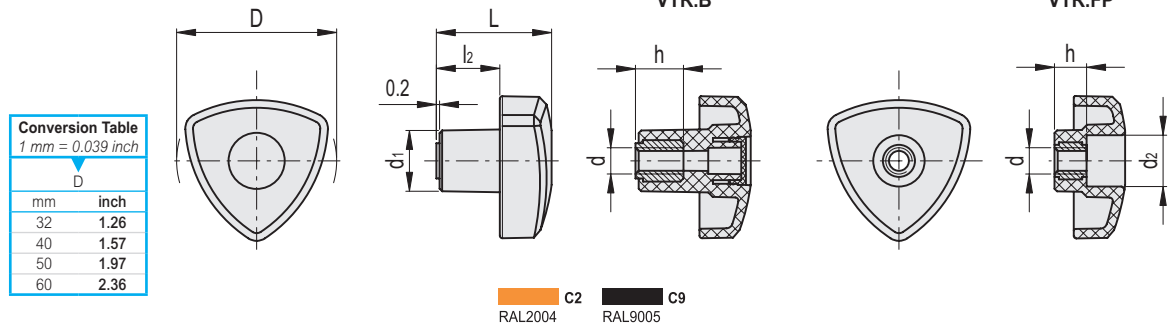

VTR-B

Code	Description	Code	Description	D	d6H	L	d1	l2	h	⚖
83002-R-C3	VTR.32-C2-B-M5-C3	83001-R-C3	VTR.32-C9-B-M5-C3	32	M5	26	14	16	10	7
83012-R-C3	VTR.32-C2-B-M6-C3	83011-R-C3	VTR.32-C9-B-M6-C3	32	M6	26	14	16	12	9
83402-R-C3	VTR.40-C2-B-M6-C3	83401-R-C3	VTR.40-C9-B-M6-C3	40	M6	30	16	17	12	11
83412-R-C3	VTR.40-C2-B-M8-C3	83411-R-C3	VTR.40-C9-B-M8-C3	40	M8	30	16	17	14	13
83802-R-C3	VTR.50-C2-B-M8-C3	83801-R-C3	VTR.50-C9-B-M8-C3	50	M8	35	19	19	14	18
83812-R-C3	VTR.50-C2-B-M10-C3	83811-R-C3	VTR.50-C9-B-M10-C3	50	M10	35	19	19	16	22
84202-R-C3	VTR.60-C2-B-M10-C3	84201-R-C3	VTR.60-C9-B-M10-C3	60	M10	41	22	22	16	30
84212-R-C3	VTR.60-C2-B-M12-C3	84211-R-C3	VTR.60-C9-B-M12-C3	60	M12	41	22	22	18	32

VTR-FP

Code	Description	D	d6H	L	d1	d2	l2	h	⚖
83021	VTR.32 FP-M5	32	M5	14	14	10	4	6	5
83421	VTR.40 FP-M6	40	M6	18	16	12	5	8	8
83821	VTR.50 FP-M8	50	M8	22	19	16	6	10	14
84221	VTR.60 FP-M10	60	M10	26	22	19	7	12	22

Clamping knobs

Conversion Table 1 mm = 0.039 inch	
D	
mm	inch
32	1.26
40	1.57
50	1.97
60	2.36

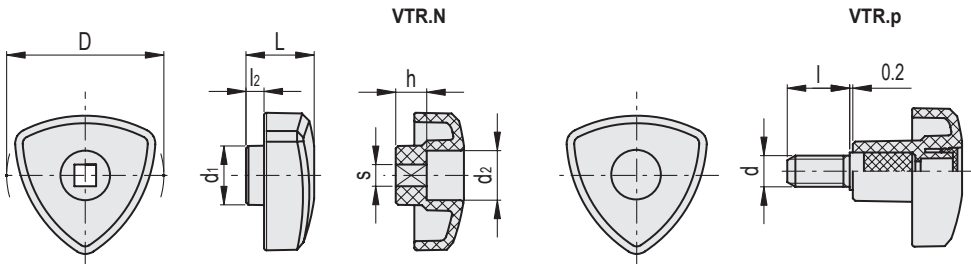

VTR-N

METRIC

Code	Description	D	sH9	L	d1	d2	l2	h	⚖
83031	VTR.32 N-5x5	32	5	14	14	10	4	6	4
83431	VTR.40 N-6x6	40	6	18	16	12	5	8	7
83831	VTR.50 N-6x6	50	6	22	19	16	6	10	12
83836	VTR.50 N-7x7	50	7	22	19	16	6	10	11
84231	VTR.60 N-7x7	60	7	26	22	19	7	12	18

VTR-p

Code	Description	D	d6g	L	d1	l	l2	⚖
83041-R-C3	VTR.32-C9-p-M5x10-C3	32	M5	26	14	10	16	9
83042-R-C3	VTR.32-C9-p-M5x20-C3	32	M5	26	14	20	16	10
83043-R-C3	VTR.32-C9-p-M5x40-C3	32	M5	26	14	40	16	13
83051-R-C3	VTR.32-C9-p-M6x10-C3	32	M6	26	14	10	16	10
83052-R-C3	VTR.32-C9-p-M6x20-C3	32	M6	26	14	20	16	13
83053-R-C3	VTR.32-C9-p-M6x40-C3	32	M6	26	14	40	16	15
83441-R-C3	VTR.40-C9-p-M6x10-C3	40	M6	30	16	10	17	14
83442-R-C3	VTR.40-C9-p-M6x20-C3	40	M6	30	16	20	17	15
83443-R-C3	VTR.40-C9-p-M6x40-C3	40	M6	30	16	40	17	19
83451-R-C3	VTR.40-C9-p-M8x16-C3	40	M8	30	16	16	17	19
83452-R-C3	VTR.40-C9-p-M8x30-C3	40	M8	30	16	30	17	25
83453-R-C3	VTR.40-C9-p-M8x50-C3	40	M8	30	16	50	17	30
83841-R-C3	VTR.50-C9-p-M8x16-C3	50	M8	35	19	16	19	28
83842-R-C3	VTR.50-C9-p-M8x30-C3	50	M8	35	19	30	19	32
83843-R-C3	VTR.50-C9-p-M8x50-C3	50	M8	35	19	50	19	37
83851-R-C3	VTR.50-C9-p-M10x20-C3	50	M10	35	19	20	19	35
83852-R-C3	VTR.50-C9-p-M10x30-C3	50	M10	35	19	30	19	40
83853-R-C3	VTR.50-C9-p-M10x50-C3	50	M10	35	19	50	19	50
84241-R-C3	VTR.60-C9-p-M10x20-C3	60	M10	41	22	20	22	46
84242-R-C3	VTR.60-C9-p-M10x30-C3	60	M10	41	22	30	22	48
84243-R-C3	VTR.60-C9-p-M10x50-C3	60	M10	41	22	50	22	60
84251-R-C3	VTR.60-C9-p-M12x20-C3	60	M12	41	22	20	22	57
84252-R-C3	VTR.60-C9-p-M12x30-C3	60	M12	41	22	30	22	65
84253-R-C3	VTR.60-C9-p-M12x50-C3	60	M12	41	22	50	22	80



Clamping knobs